

與之配合之包壳

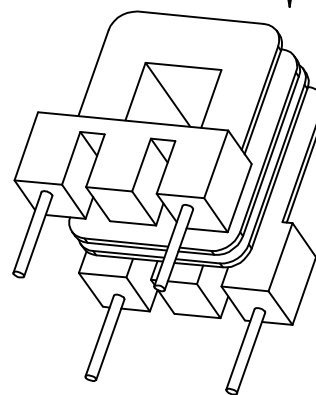

		TOLERANCE:		DECIMAL X±0.3		CHECK	黃勇
		PIN PITCH±0.1		.XX±0.2			
		ROW PITCH±0.3					
修改前尺寸	修改後尺寸	SHEET OF		REV.	DRAWING		宋耀林
深圳中晟磁电有限公司 Shenzhen CB Magnetics Co., Limited		TEL	0755-61124460	MODEL	EI19X5 BOBBIN(4 PIN)		
		FAX	0755-61124460	MATERIAL	PBT		
		UNIT	m/m	PART NO.	DG-EI19X5H-4-3-PBT	DATE	2009.10.5