

## SPECIFICATION

客戶/CUSTOMER		規格型號/TYPE	EE20 Horizontal 5+5PIN	制定日期/DATA	2022/4/2
客戶料號/C.P.O		生產料號/ZC NO.	DG-T-EE20-01	版本/VERSION	REV.A

### 1. 外觀尺寸/ PHYSICAL DIMENSION ( UNIT: m/m ) :

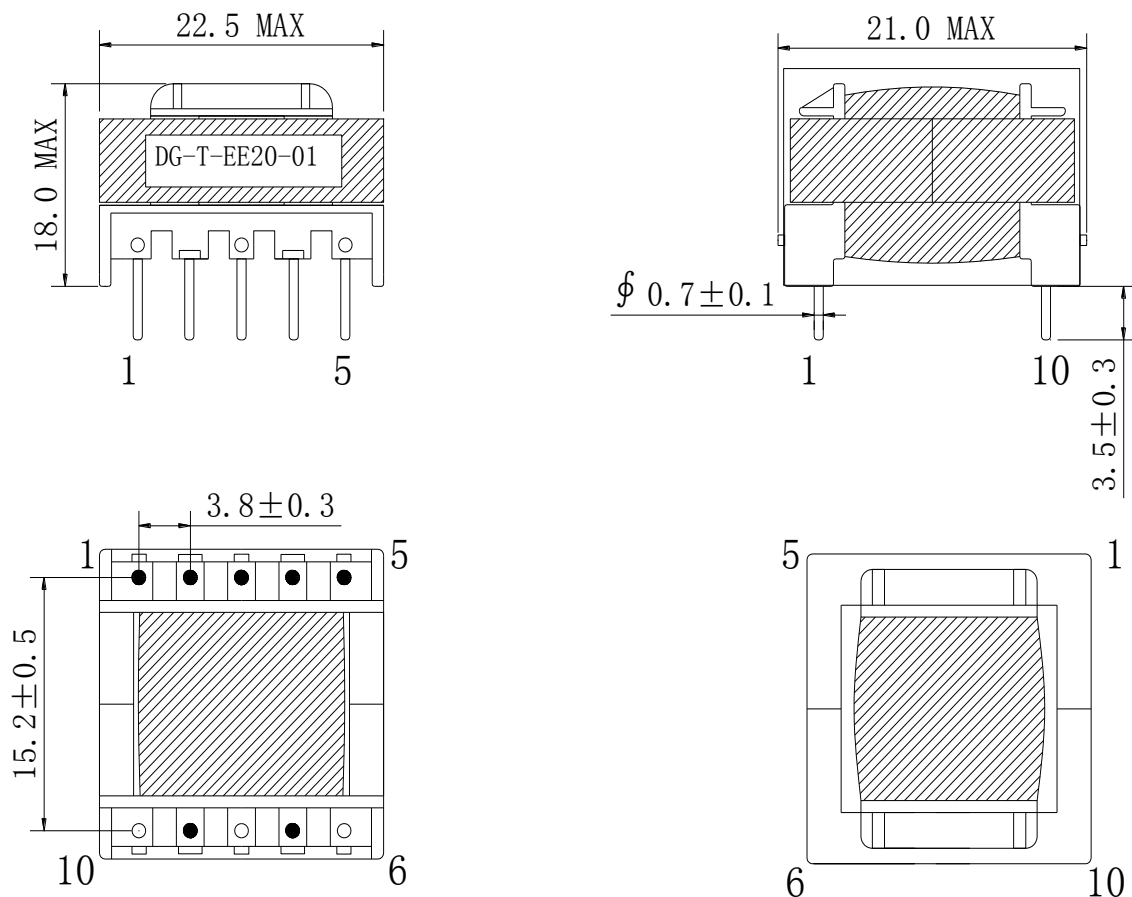

#### 备注:

- \* Bobbin PIN6,8,10 CUT OFF
- \* Core with GAP, Core fixed the side of PIN6-10, using 3TS 5.5mm tapes Grapped
- \* Products ROHS compliant, PIN1,PIN2 share the same slot
- \* 产品需真空含浸 Product requires vacuum impregnation
- \* 标签: ( 透明底黑字或印制 )  
Label: ( Black text on transparent background or printed )



確認/APPROVAL

Haitao Huang

審核/CHECKED

Yong Yuan

制定/PREPARED

Anbing Deng

## SPECIFICATION

客戶/CUSTOMER		規格型號/TYPE	EE20 Horizontal 5+5PIN	制定日期/DATA	2022/4/2
客戶料號/C.P.O		生產料號/ZC NO.	DG-T-EE20-01	版本/VERSION	REV.A

### 2. 原理圖/SCHEMATIC :

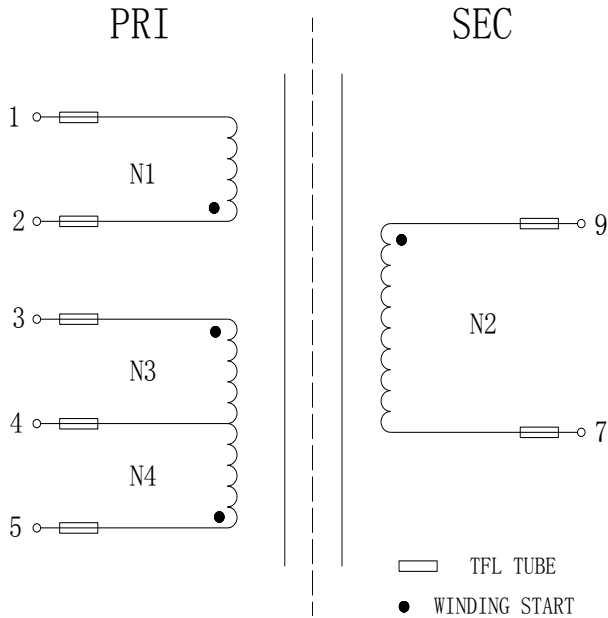

### 3. 繞組示意/WINDING SCHEMATIC :

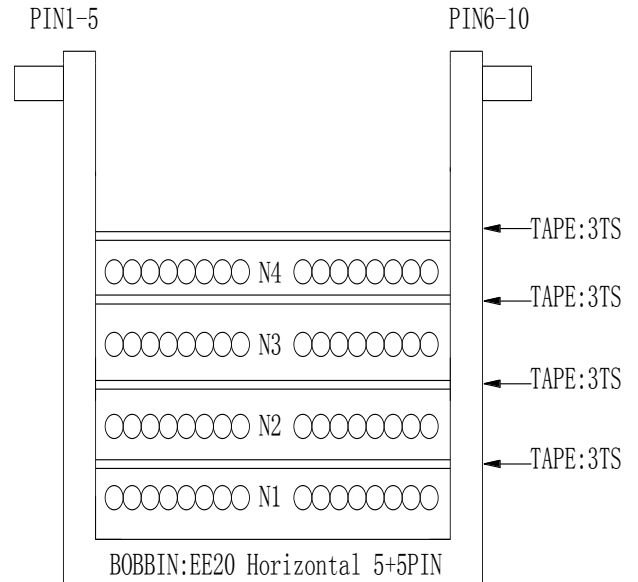

#### Remark:

- \* 繞線時PIN1固定朝外，順時針繞線，繞組進出線須加TFL TUBE，繞線排列要平整、均勻、緊密。  
When winding, PIN1 should be fixed outward, and the winding should be clockwise. TFL TUBE must be added to the winding input and output wires, and the winding arrangement should be flat, uniform and tight.
- \* PIN1,PIN2脚共槽  
PIN1, PIN2 share the same slot



確認/APPROVAL

Haitao Huang

審核/CHECKED

Yong Yuan

制定/PREPARED

Anbing Deng