

# SPECIFICATION FOR APPROVAL

CUST		CUST P/N		OUR P/N	DG-T1697-01ZS
DESCRIPTION	T16*9*7 LINE Filter	Q' TY	20 PCS	DATE	2022-1-20

### (1) PHYSICAL DIMENSIONS: (UNIT:mm)

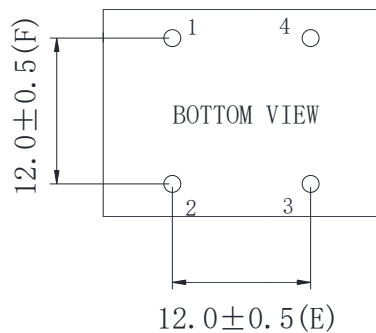
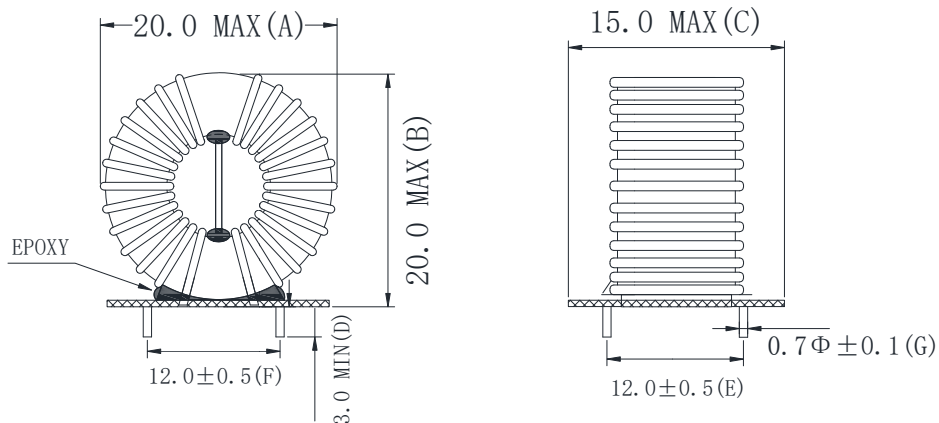

### (2) SCHEMATIC DRAWING:

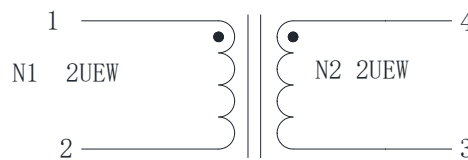

### (3) ELECTRIC CHARACTERISTIC:

1. L(1-2) & (4-3) : 8.0mH MIINN(5A) @1KHZ/0.3V
2. |L(1-2)-L(4-3)| ≤ 0.5mH
3. DCR(1-2) & (4-3) : 40mΩ MAX @25°C
4. T/R(1-2) : (4-3) = 1:1 ± 2% @ 20KHZ/1.0V
5. WINDING TO WINDING 2000VAC/5mA/2SEC

APPROVED BY	<i>Kevin Chan</i>	CHECKED BY		MADE BY	DemiDu
-------------	-------------------	------------	--	---------	--------